

PW 12 D

The Reliable Dumper.



Payload
11,500 kg | 25,400 lbs



Ground pressure
0.24 kg/cm² | 3.41 psi



Fording depth
1,300 mm | 51.2"



Tare weight
15,200 kg | 33,510 lbs



Capacity heaped
6.7 m³ | 8.8 yd³ (ISO 6483)



Gradeability
60 % uphill & downhill
40 % sidehill



Max. speed
14.5 km/h | 9.0 mph

PRODUCT KEY FEATURES

- ⊕ Transport miracle: High payloads and large loading volumes enable the transport of up to 11.5 tons of soil, rocks or other material!
- ⊕ No limitations: Thanks to its off-road driving potential, PowerBully masters uneven terrain, mud, swamps and obstacles with ease.
- ⊕ Safely and comfortable: Large windows combined with a 360° camera system and premium LED lighting provide the operator with optimal visibility. The cab suspension and large wheels provide a smooth ride through rough terrain.

TANK VOLUMES

Diesel	250 l	66 gal
AdBlue	38 l	10 gal
Hydraulic oil	52 l	14 gal

CABIN

Suspended cab 1,412 mm width
ROPS / FOPS (Level I & II) certified
Single-hand joystick operation
Adjustable operator's seat

ILLUMINATION

6 LED working lights front and rear

2 axis inclination sensor
Rear view camera
10.4" Touch Display
Armrest with controls

ENGINE & POWER

Type	Cummins B6.7 Turbo Diesel	
No. of cylinders	6	
Displacement	6.7 l	6,700 ccm
Power Output @ 2,000 rpm	209 kW	285 hp
Max. Torque @ 1,500 rpm	1,288 Nm	950 ft lb
Emission standard	EU Stage V	Tier 4f
Drive Train	Hydrostatic Bosch Rexroth drive train	

CHASSIS

Track type	Endless rubber track	
Track width	750 mm	29.5"
Frame type	C-shaped profile	
Frame width	864 mm	34"
Wheels	8 steel wheels	
Walking beam		
Automatic track tensioning		
Ground pressure (empty)	0.24 kg/cm ²	3.41 psi
Ground pressure (loaded)	0.44 kg/cm ²	6.25 psi

Heating, temperature and fan control
Air conditioning
12 V power outlet
2 USB charging ports (type A and C)

Mobile phone tray
Sun blind
Air-conditioned cup holder
Limp home mode



PowerBully[®]

PW 12 D

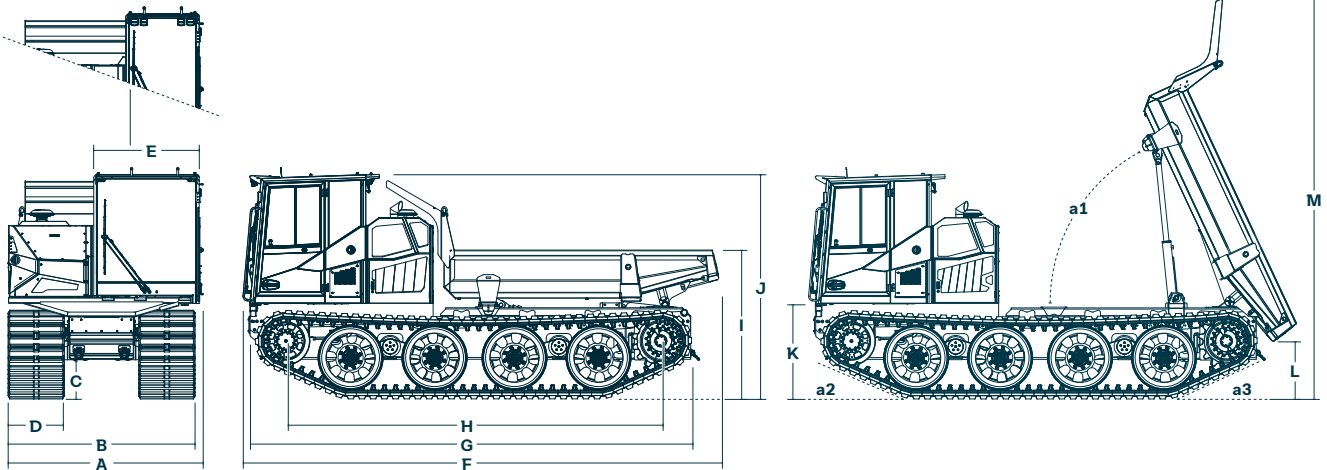

DIMENSIONS

A	2,590 mm	102"
B	2,500 mm	98"
C	532 mm	21"

D	750 mm	29.5"
E	1,412 mm	55.6"
F	6,375 mm	250"

G	5,900 mm	232.3"
H	5,021 mm	198"
I	1,992 mm	78.4"

J	3,005 mm	118"
K	1,300 mm	51.2"
L	805 mm	31.7"

M	5,314 mm	209"
---	----------	------

ANGLES

a1	58°
a2	24°
a3	26°

Optional: Narrow cab E 982 mm | 39"

Optional: Frame extension front 700 mm | 27.6" or 900 mm | 35.4"

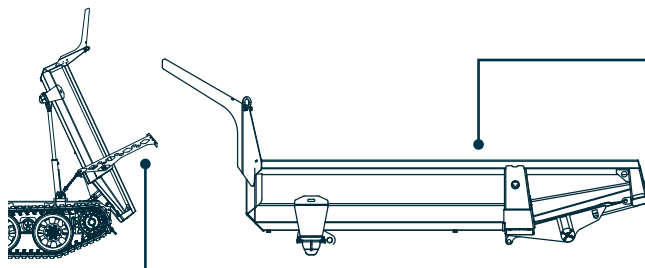

Optional: Dump box with mechanical tailgate

HARDOX DUMP BOX / AUTOMATIC LOWERING

Capacity heaped (ISO 6483)	6.7 m ³ *	8.8 yd ³ *
Capacity leveled	4.4 m ³ *	5.8 yd ³ *
Length	3,683 mm	145"
Width	2,444 mm	96"
Side wall height	652 mm	25.7"

* Applies for dump box with mechanical tailgate

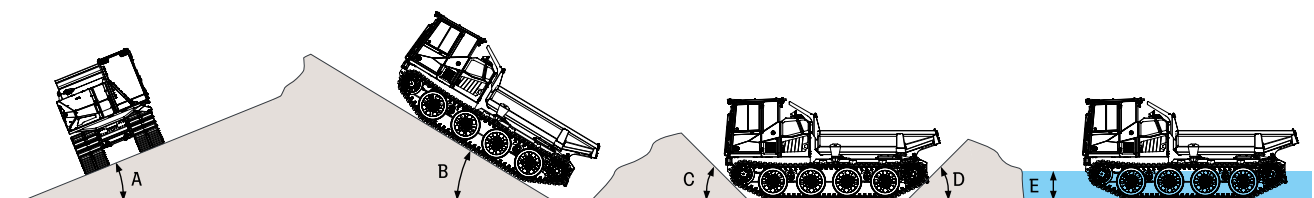

OFF-ROAD ABILITIES

A Sidehill	40% 22°	B Uphill Downhill	60% 31°	C Approach angle	45°	D Departure angle	45°	E Fording depth	1,300 mm 51.2"
------------	-----------	---------------------	-----------	------------------	-----	-------------------	-----	-----------------	------------------

Approach and departure angles deviating with frame extensions

OPTIONS

Safety

- Premium LED working lights
- Beacon light
- Auxiliary lights (High and low beam, rear light, indicators)
- 360° camera (on request)
- Foldable front protective grid
- FOPS level II protective grid
- Hydraulic winch (Tractive force: 11 t | 24,251 lbs)

Comfort

- Air suspended comfort seat
- Adjustable steering wheel
- Heated, electrically adjustable mirrors
- Radio with bluetooth and a hands-free kit

Cold start

- Heated fuel filter
- Feeder pressure reduction
- Engine block heater 230 V / 110 V
- Electrical Hydraulic Oil Heating 230 V / 110 V
- Auxiliary heating

Other

- Telematics
- Reversible fan
- Frame extension (front) 700 - 900 mm | 27.6" - 35.4"
- Narrow cab
- Trailer coupling
- Air-intake in steel-version
- Cyclonic pre-separator for air intake



Get in touch
Fast. Direct. Personal.
Scan the code to find your contact.

www.powerbully.com



KÄSSBOHRER GELÄNDEFahrzeug AG